



# SERVICE BULLETIN

No. 389

Piper Aircraft Corporation

Lock Haven, Pennsylvania, U.S.A.

"FAA DOA EA-1 Approved"

August 13, 1973

Subject: Bridle Cable and Bridle Cable Clamp Inspection; AltiMatic V and AltiMatic V Flight Director Series Automatic Flight Control Systems

Models Affected: Aircraft specified below with V and V Flight Director Series Automatic Flight Control Systems installed only:

PA-23-250 (Six Place) Aztec  
PA-31 Navajo  
PA-31P Navajo  
PA-31-350 Navajo Chieftain

Serial Numbers Affected:

27-4053, 27-4574 to 27-7305162 incl.  
31-620, 31-712 to 31-7300966 incl.  
31P-3 to 31P-7300164 incl.  
31-5001 to 31-7305099 incl.

Compliance Time:

1. Above referenced aircraft with 300 hours or less total time in operation; inspect within the next 25 hours of operation.
2. Above referenced aircraft with more than 300 hours total time in operation; inspect within the next 100 hours of operation.

Purpose: Two reports have been received which described the slippage of the roll servo bridle cable clamps on the above referenced aircraft. It appears possible that the lock nuts used in the bridle cable clamp assemblies may have loosened, causing subsequent bridle cable clamp slippage. This condition can normally be prevented by routine inspections of the Automatic Flight Control System components as specified in the appropriate Piper periodic inspection forms, airplane service manuals and appropriate Automatic Flight Control System service manuals.

This service release is submitted to amplify the necessity of close adherence to recommended routine inspection procedures and contains instructions to inspect the V and V Flight Director Series Automatic Flight Control System bridle cable and bridle cable clamp for proper installation and security.

Instructions: Reference attached sketch/instruction sheet.

Material Required: Not applicable.

(over)

Availability of Parts:

Not applicable.

Effectivity Date:

This Service Bulletin is effective August 24, 1973.

Summary:

Please contact your Piper Dealer to make arrangements for compliance with this Service Bulletin in accordance with the provisions of Compliance Time, above. One and one half (1 1/2) hours labor allowance is provided free of charge, as long as this inspection is accomplished by a Piper Dealer.

A Service Publication Compliance form is enclosed with copies of this Service Bulletin being mailed to owners/operators of above referenced aircraft. Following compliance with the provisions of this Service Bulletin, this form must be filled out per instructions on the reverse side of the form bottom copy and left with the Piper Dealer performing the inspection.

**V SERIES AUTOPILOT BRIDLE CABLE AND BRIDLE CABLE CLAMP INSTALLATION  
AND SECURITY INSPECTION**

(PA-23-250 (Six Place) Roll and Pitch Servo Capstan Assembly Installations)  
(PA-31, PA-31-350 and PA-31P Roll Servo Capstan Assembly Installations)

INSTRUCTIONS

1. Refer to the AltiMatic V and AltiMatic V-1 Service Manual (P/N 761 525) or the AltiMatic V F/D and AltiMatic V F/D-1 Service Manual (P/N 761 526) to gain access to the Roll and/or Pitch Servo Capstan Assembly.
2. Loosen the nuts on the bridle cable clamps - one at a time, then retighten; ascertain that the MS20365-1032C nuts retain their self-locking capabilities. If the nuts run freely on the AN3-6A bolts, replace nuts as required.
3. Check the control cable and bridle cable tension in accordance with the Roll and/or Pitch Servo Capstan Assembly Installation Instructions in the appropriate V Series Service Manual.
4. Torque the bridle cable clamp bolts to 23 + 2 inch-pounds, above the nut running torque.
5. Check for proper position and security of bridle cable clamps and for proper servo function as outlined in the roll and/or pitch servo installation instruction in the appropriate V Series service manual.
6. Install all carpet, seats and panels previously removed and secure.

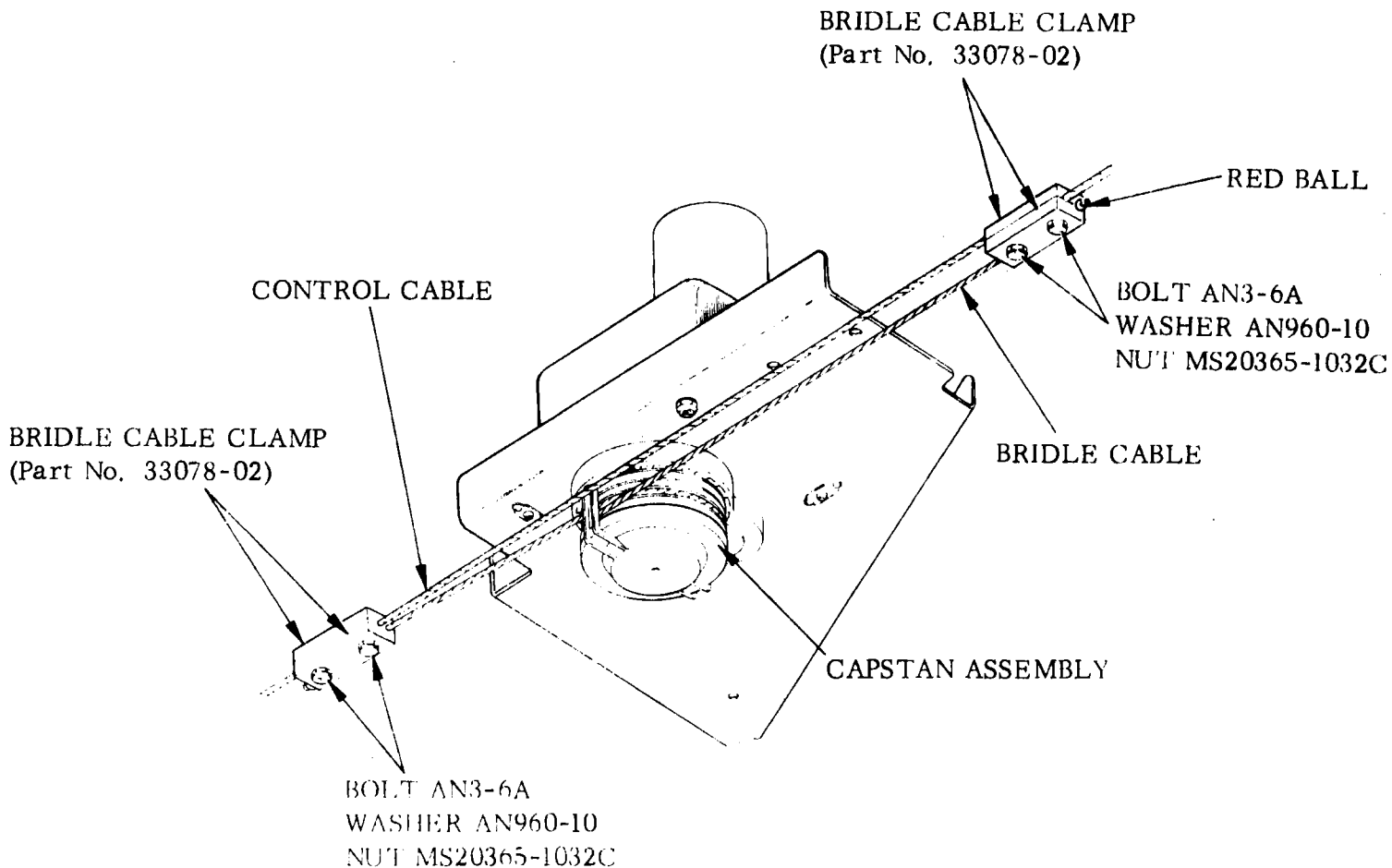

TYPICAL BRIDLE CABLE INSTALLATION  
(PA-31 Series Roll Servo Shown)